

Ideal Diode Controller

General Description

The EM5237B is an advanced high voltage, ideal diode controller that drives an internal N-channel MOSFET to replace Schottky diode. It controls the forward-voltage drop across the MOSFET to ensure smooth current delivery without oscillation from one path to the other. It includes under voltage lockout and over temperature protection. This part is available in DFN3310 package.

Ordering Information

| Part Number | Package | Note |
|-------------|---------|--------------------------------------|
| EM5237BVQA | DFN3310 | Single Channel, 6A Ron: 12mΩ(TYP) |

Features

- Wide Input Range 4.5V to 24V
- Dual Integrated N-Channel MOSFET
- Low 100μA Operating Current
- Reduces Power Dissipation by Replacing Schottky Diode
- Smooth Switchover Without Oscillation
- Control Single or Dual N-Channel MOSFETs
- Protection Circuitry: UVLO

Applications

- Input Power Path Management
- USB PD
- High Side Power Protection Switches

Typical Application Circuit

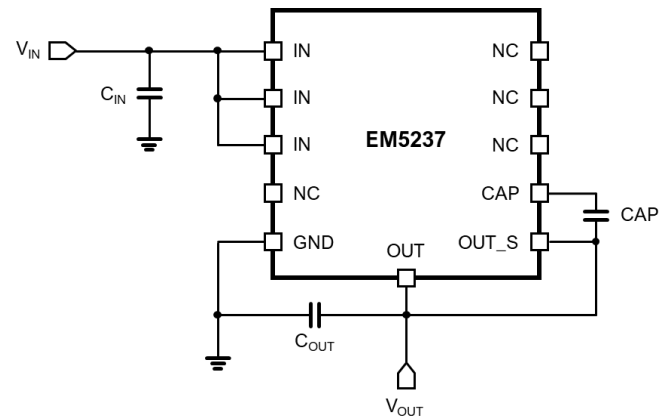

Pin Configuration

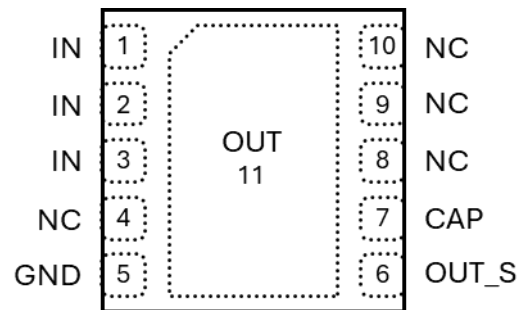

EM5237VQA(DFN3X3-10)

Function Block

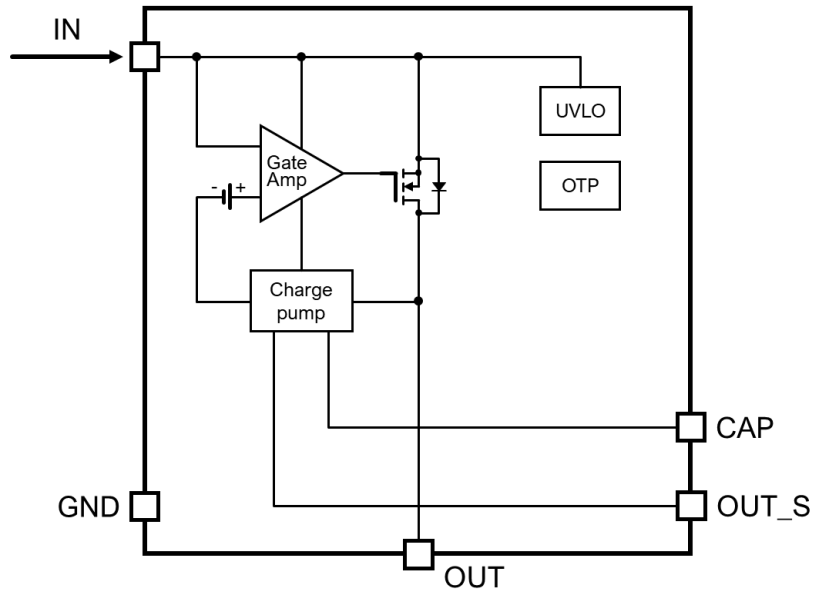

Pin Assignment

| Pin Name | DFN3310 Pin No. | Pin Function (EM5237B) |
|----------|-----------------|--|
| IN | 1/2/3 | Input Voltage. Input Power Supply (Primary or Auxiliary Supply) |
| NC | 4/8/9/10 | NC. Do not connected. |
| GND | 5 | GND |
| OUT_S | 6 | Output Sensing, it must be connected to output terminal |
| CAP | 7 | CAP. An external capacitor to GND for internal charge pump circuit |
| VOUT | EP | Output. Connect to the output rail |

Absolute Maximum Rating (Note1, 2, 3)

- IN, OUT, OUT_S ----- -0.3V to +28V
- CAP to OUT_S ----- -0.3V to +7V
- Power Dissipation, P_D @ $T_A = 25^\circ\text{C}$, DFN3310 ----- 1.67 W
- Package Thermal Resistance, θ_{JA} , DFN3310 ----- $60^\circ\text{C}/\text{W}$
- Maximum Junction Temperature ----- -40°C to 150°C
- Storage Temperature ----- -65°C to 150°C
- ESD Rating, HBM (Human Body Mode) ----- 2kV
- ESD Rating, MM (Machine Mode) ----- 200V
- ESD Rating, CDM (Charge Device Mode) ----- 500V

Recommended Operating Conditions (Note4)

- IN, OUT, OUT_S ----- 4.5V to +24V
- CAP to OUT_S ----- 0V to +6V
- Operating Junction Temperature ----- -40°C to 125°C
- Operating Ambient Temperature ----- -40°C to 85°C

Electrical Characteristics

$V_{IN}=20\text{V}$, $T_A=25^\circ\text{C}$, unless otherwise specified

| Parameter | Symbol | Test Conditions | Min | Typ | Max | Units |
|---------------------------------|--------------|--|-----|-----|-----|------------------|
| Input Section | | | | | | |
| Input Supply Range | V_{IN} | Internal VIN POR | 4.5 | | 24 | V |
| Under Voltage Lockout Voltage | V_{UVLO} | In Pin | | 3.6 | | V |
| POR Hysteresis | V_{PORHYS} | | | 100 | | mV |
| INPUT Operating Current | I_Q | No load | | 100 | | μA |
| Source-Drain Regulation Voltage | V_{SD} | VSD In Regulation | | 30 | | mV |
| Switch Section | | | | | | |
| On Resistance | R_{ON} | $I_{LOAD}=1\text{A}$, $V_{IN}= 4.5\text{V}$ to 24V | | 12 | | $\text{m}\Omega$ |

Note 1. Stresses listed as the above “Absolute Maximum Ratings” may cause permanent damage to the device. These are for stress ratings. Functional operation of the device at these or any other conditions beyond those indicated in the operational sections of the specifications is not implied. Exposure to absolute maximum rating conditions for extended periods may remain possibility to affect device reliability.

Note 2. θ_{JA} is measured in the natural convection at $T_A=25^\circ\text{C}$ on a low effective thermal conductivity test board (2-layer) of JEDEC 51-3 thermal measurement standard.

Note 3. Devices are ESD sensitive. Handling precaution is recommended.

Note 4. The device is not guaranteed to function outside its operating conditions.

TYPICAL PERFORMANCE CHARACTERISTICS

Test Conditions: $I_N = 20\text{ V}$, $T_A = 25^\circ\text{C}$ and natural convection cooling, unless otherwise noted

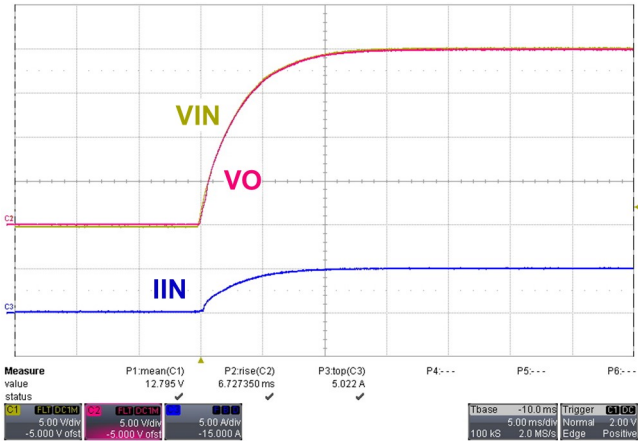

Figure.1 $I_N = 20\text{ V}$, $R_o = 4\Omega$, Power on

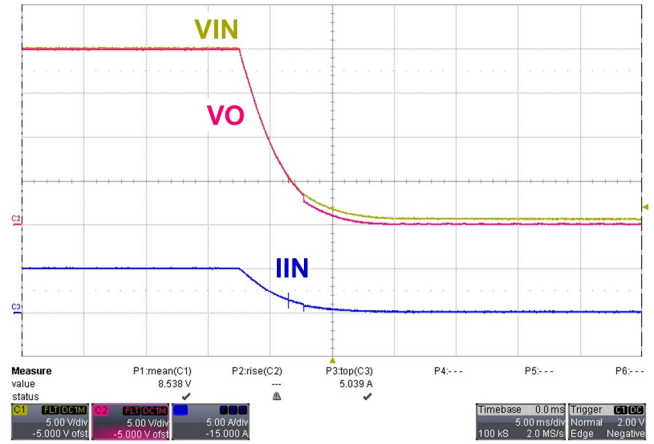
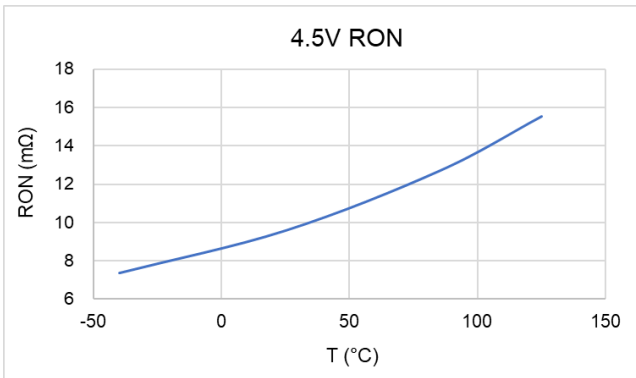
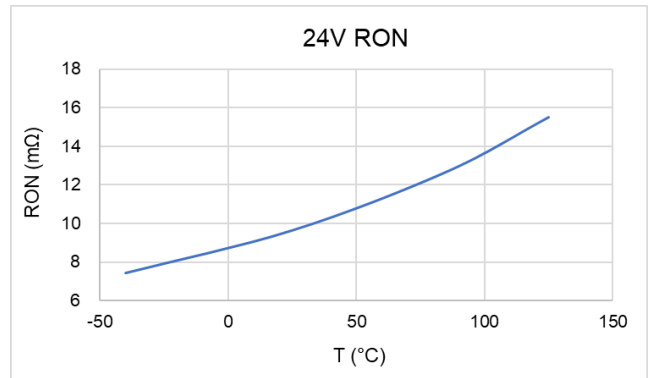

Figure.2 $I_N = 20\text{ V}$, $R_o = 4\Omega$, Power off



RON @ $I_N = 4.5\text{ V}$ vs Temperature



RON @ $I_N = 24\text{ V}$ vs Temperature

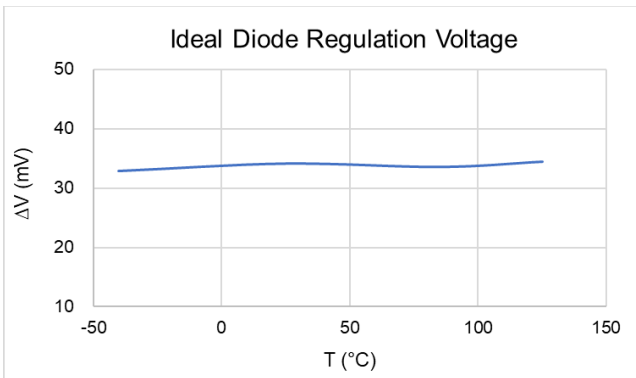

VSD vs Temperature

Ordering & Marking Information

Device Name: EM5237B for DFN3.0X3.0-10



→ EM5237B Device Name

→ ABCDEFG: Date Code

1

Outline Drawing

DFN3.0X3.0-10

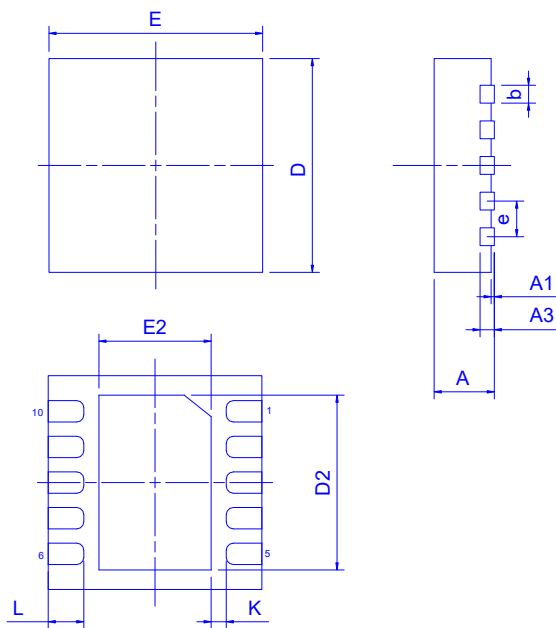

Dimension in mm

| Dimension | A | A1 | A3 | b | D | E | D2 | E2 | e | L | K |
|-----------|------|------|-----|------|-----|-----|------|------|------|------|------|
| Min. | 0.7 | 0.00 | | 0.18 | | | 2.20 | 1.40 | | 0.30 | 0.20 |
| Typ. | 0.75 | 0.02 | 0.2 | 0.25 | 3.0 | 3.0 | | | 0.50 | 0.40 | |
| Max. | 0.80 | 0.05 | | 0.30 | | | 2.70 | 1.75 | | 0.50 | |

Footprint

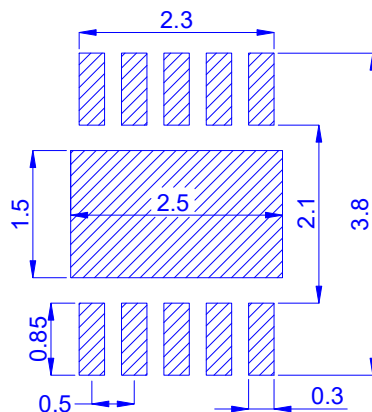

◆ Tape&Reel Information: 5000pcs/Reel

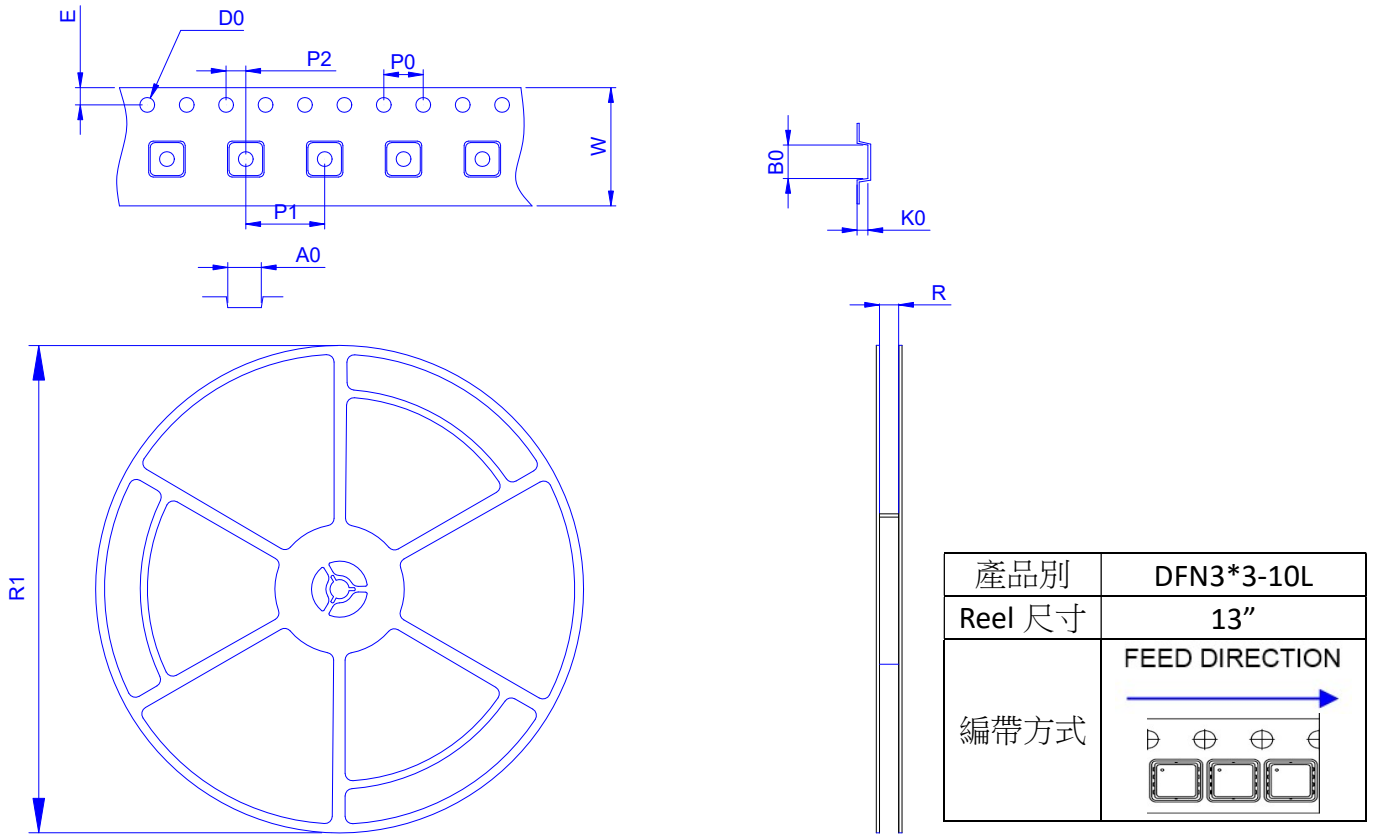

Dimension in mm

| z | Carrier tape | | | | | | | | | Reel | |
|------|--------------|------|------|------|------|------|------|------|-------|-------|--------|
| | A0 | B0 | D0 | E | K0 | P0 | P1 | P2 | W | R | R1 |
| Typ. | 3.30 | 3.30 | 1.50 | 1.75 | 1.10 | 4.00 | 8.00 | 2.00 | 12.00 | 12.40 | 330.00 |
| ± | 0.30 | 0.20 | 0.20 | 0.20 | 0.40 | 0.20 | 0.20 | 0.20 | 0.50 | REF | REF |